

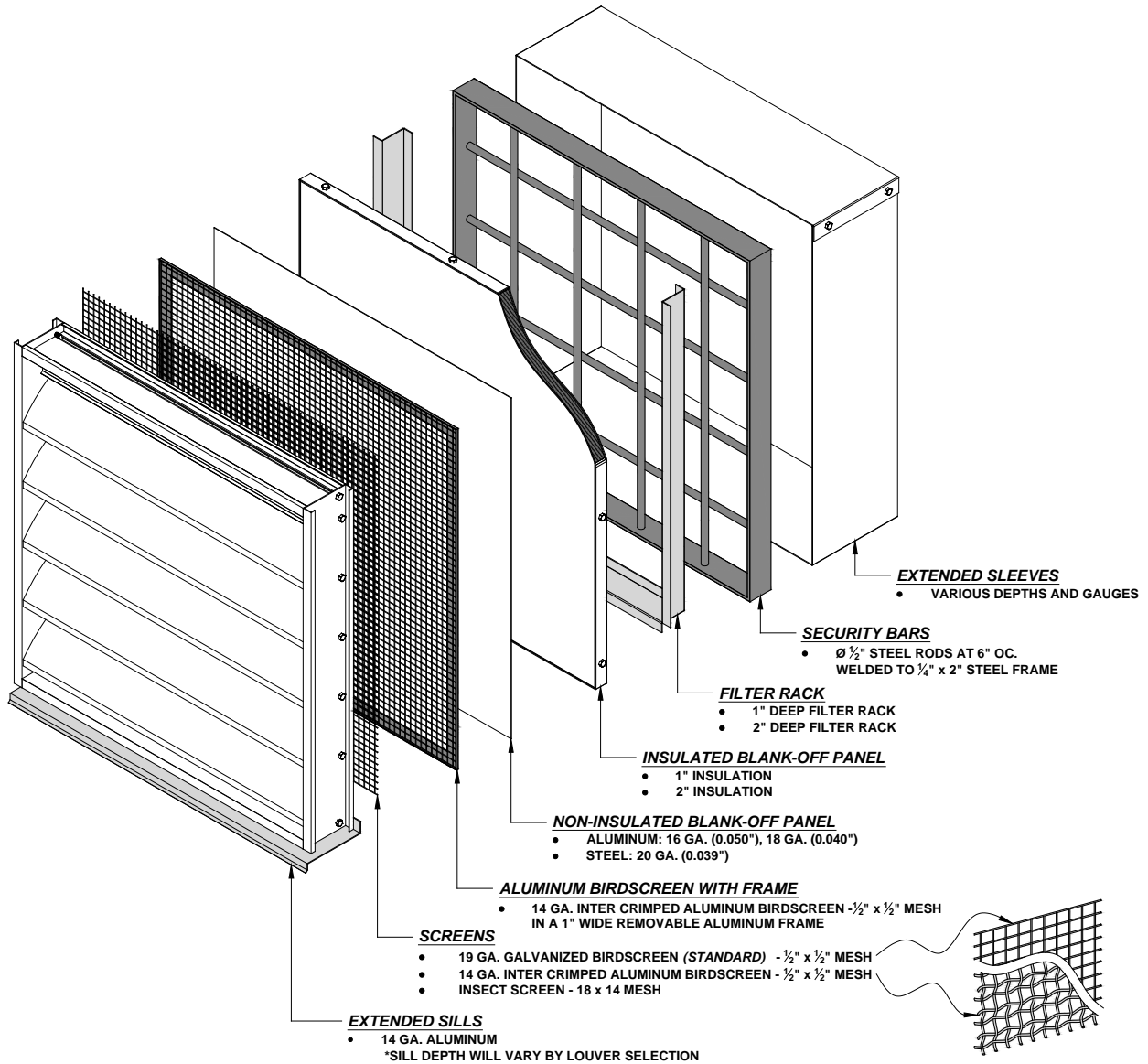

LOUVERS & BACK DRAFT DAMPERS

AVAILABLE ACCESSORIES



AVAILABLE FINISHES:

- BAKED ENAMEL FINISH
- DURANAR FINISH
- ANODIZED FINISH
 - CLEAR ANODIZED
 - LIGHT BRONZE
 - MEDIUM BRONZE
 - DARK BRONZE
 - BLACK ANODIZED

OTHER ACCESSORIES:

- STAINLESS STEEL FASTENERS
- ALL WELDED CONSTRUCTION
- MONUMENTAL CONSTRUCTION WITH HEAVY GAUGE MATERIAL (AVAILABLE FOR MODELS 2420 AND 2630 ONLY)



LOUVERS & BACK DRAFT DAMPERS

AVAILABLE ACCESSORIES

CONTINUOUS LINE CONSTRUCTION

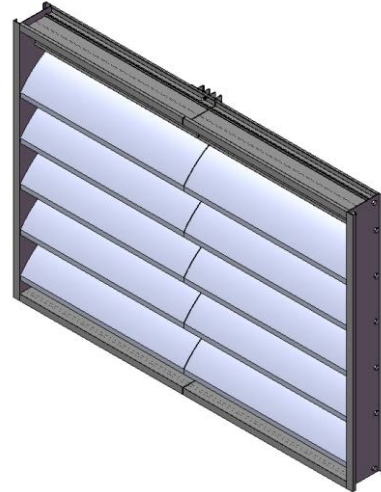
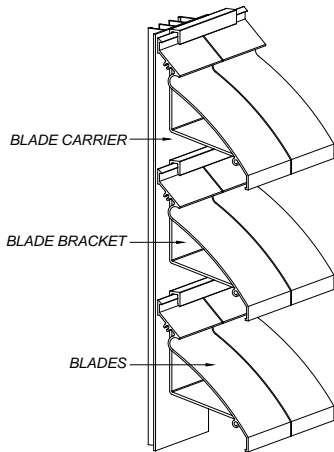

*NOT RECOMMENDED FOR DRAINABLE LOUVERS

HINGED ACCESS DOORS

SECTION - X

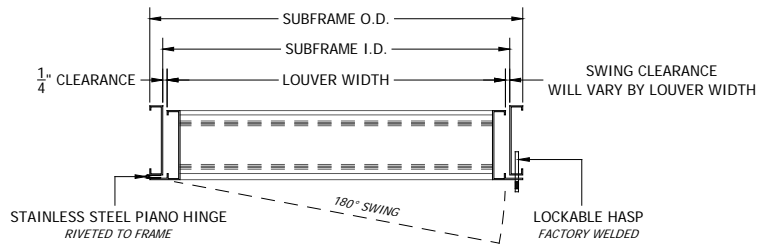

SECTION - Y

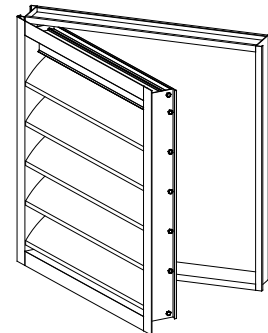
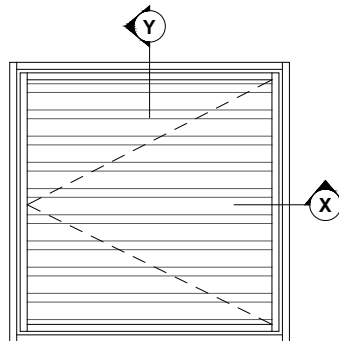
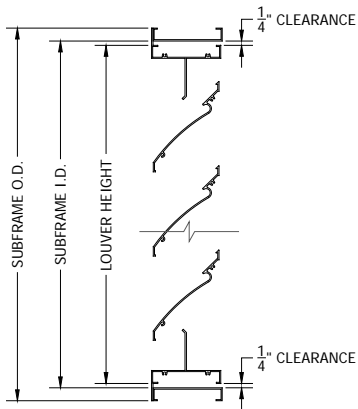



LOUVERS & BACK DRAFT DAMPERS

AVAILABLE ACCESSORIES

SPECIALTY GEOMETRIC SHAPES

ARC

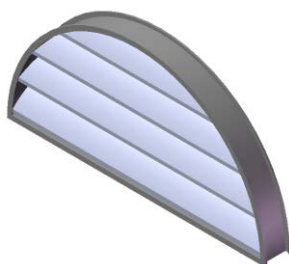

ARCHED

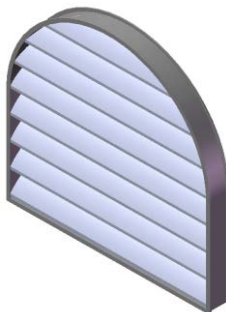

ROUND

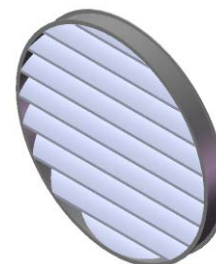

TRIANGLE



PEAKED TOP

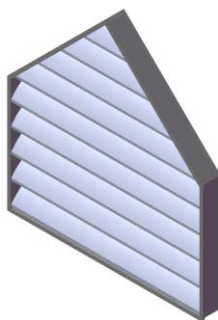

DIAMOND

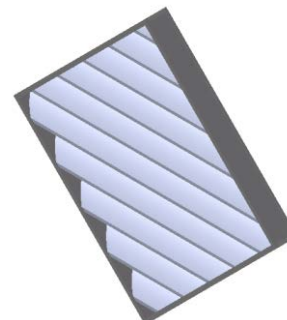

PARALLELOGRAM

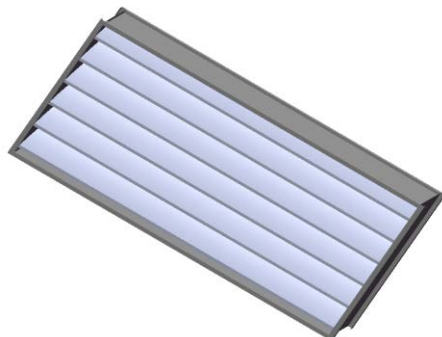

TRAPEZOID



OCTAGON

